



GENERATION 3 | 3-PHASE + STACKABLE BATTERY

INSTALLATION MANUAL

- 3HY 6.0, 3HY 8.0, 3HY 10.0, 3HY 11.0
- 10.2 HV, 13.6 HV, 17.0 HV, 20.4 HV

Before installation, the following tools are required:

Item	Item Name
A	Drill
B	Suitable drill bit for wall and fixings
C	Set of Allen keys
D	Multimeter
E	Knife
F	Wire cutters
G	Wire strippers
H	Crimping tool
I	Socket set for wall bolts
J	Tape measure and spirit level
K	Pen/pencil
L	RJ45 crimping tool (for making own LAN cable)
M	USB stick (for updating firmware)
N	Laptop/tablet/phone with internet connection for commissioning
O	Insulated screw drivers

Note: Please adhere to best practices and local legislation for manual handling processes when moving, lifting and installing the equipment.



A TRUE MULTITASKER Hybrid Inverter

The 3-phase GivEnergy Hybrid Inverter is a battery inverter and solar inverter in one unit, meaning that the battery is AC and DC coupled.

It can be coupled directly with solar panels to generate usable electricity in the property, as well as store any excess energy in the battery for later use. It features easy plug and play installation and on / off grid phase balancing. Additionally , it will minimise import by discharging to meet demand in the property with a discharge rate of up to 11kW.

The unit can also be used as an AC coupled alongside existing solar installations.

Specifications

Dimensions

658H x 214D x 480W (mm)

Weight

35 Kg

Charge / Discharge Efficiency

97.6% / 96%

PV Max. Efficiency

97.9%

Warranty

12 years

Operational temperature

-25°C - 60°C (derating at 50°C)

Start Up Voltage

200V

Max. DC Input Power

6.0kW	-	9kW
8.0kW	-	12kW
10.0kW	-	15kW
11.0kW	-	15kW

Item	Item Name	Qty
A	Inverter	1
B	Wall Mounting Bracket	1
C	Bolt to Secure Inverter to Mounting Bracket	2
D	Mounting Bracket Fixings	5

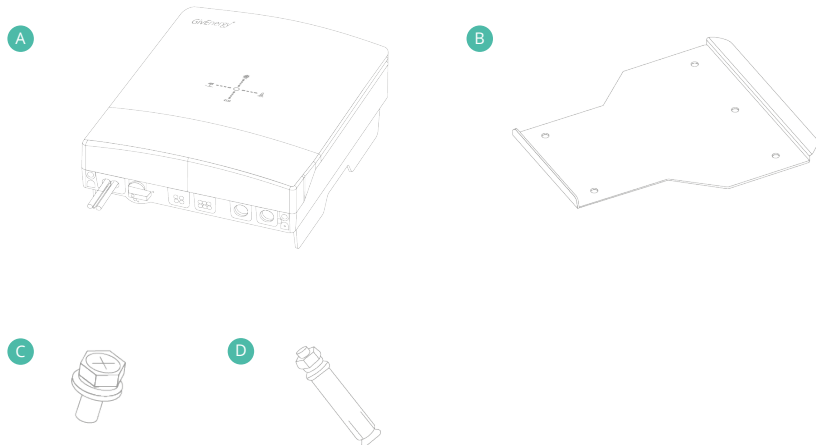

Introduction

All information contained in this booklet refers to the assembly, installation, commissioning, and maintenance of the 3-Phase Hybrid Inverter. Please retain this manual for future reference.

Legal Disclaimer: This document is the property of GivEnergy, reproduction is prohibited.

Installation Requirements

Installation of all GivEnergy equipment must be carried out by an **Approved Installer**.

Please ensure that there is sufficient space and ventilation around the inverter and battery before installation.

Unit Information

The 3-Phase Hybrid Inverter is a battery inverter and PV inverter in one. It is bi-directional, meaning it can charge from the grid (AC coupled) and from solar (DC coupled). It can also charge from existing solar installations.

Storing the Inverter

The unit must be stored in its original packaging at temperatures between 25°C - 60°C. Do not stack more than 4 units on top of each other.

Packaging Contents

When unpacking, please check the following:

- ✔ There are no missing accessories from the packaging list
- ✔ The model and specification of the inverter's nameplate match the order specifications

If any damaged or missing parts are found, please contact GivEnergy on email **info@en-ga.com** immediately. Returns must be provided in original or equivalent packaging. The cardboard packaging is recyclable.

Item	Item Name
A	Power Flow Direction Indicators
B	Battery connection point
C	PV Input Switch
D	PV Input Terminals
E	4G Module USB Port (Optional)
F	Communication Ports
G	AC Supply Terminals (Right) and EPS Terminals (Left)
H	Serial No.
I	WiFi Serial No. and Verification Code
J	Warning Signs Label
K	Specification Label
L	Heat Sink

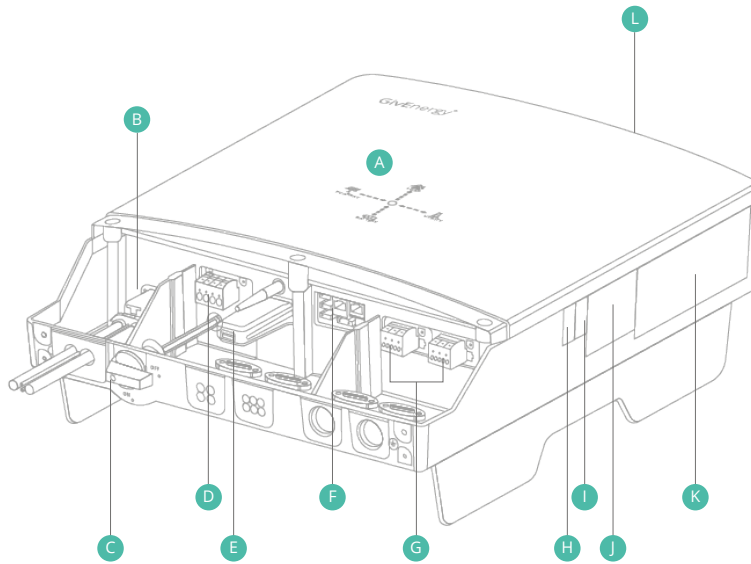

Safety Instructions

Extra care and attention must be taken when installing and maintaining any GivEnergy equipment. The system is capable of retaining a high voltage, even when disconnected.

- ✔ If you suspect something is wrong with the inverter, contact GivEnergy on **01377 252 874** or email **support@givenergy.co.uk**
- ✔ If there are any damaged or missing parts, please contact the distributor immediately. Returns must be provided in original or equivalent packaging
- ✔ All electrical installations must be carried out by a qualified and registered electrician and in accordance with local wiring regulations
- ✔ During operation, the heat sink may become hot. Do not touch the heat sink at the sides, or the top of the inverter when in operation
- ✔ The inverter is designed to be connected to the grid; connecting your inverter to a generator or other power source can result in damage to the inverter or external devices
- ✔ All GivEnergy equipment must be installed by a GivEnergy Approved Installer



The inverter must be installed in an easily accessible location, the status display must be visible and not obstructed



Please ensure that the wall to be mounted on is sufficient enough to hold the weight of the inverter and battery pack



The inverter must be installed in a well ventilated area with 30cm clearance around it, free of any obstacles. The ambient temperature should be below 40°C to ensure optimal operation



The inverter must be installed vertically with connections always positioned at the bottom, never install horizontally, and avoid tilting the unit



Do not install in direct sunlight or near water sources



Mount the inverter at least 3 feet above ground level (outside only)

Precautions

- Only GivEnergy supplied battery cables must be used
- Only GivEnergy batteries should be connected to our inverters
- Reversed polarity may damage the inverter

1. Please ensure that there is sufficient space and ventilation around the inverter and battery before installation.

Note: Take into consideration that batteries may be added at a later date. To allow for this, hang the inverter higher to ensure there is enough space.

If installing the products outside: make sure the products are not in direct sunlight, and are situated in a location where the inverter remains within operating temperatures. This is to ensure the unit remains fully functional.

2. The bracket is attached to the inverter when in the box. Take off the 2 bolts at the bottom to remove the bracket.

3. Wall thickness should be suitable to hold the weight of the inverter. Place the wall mounting bracket horizontally onto the wall and mark the position for the bracket holes.

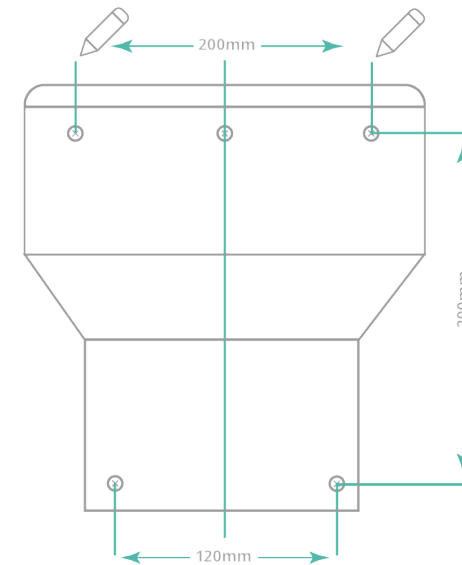

4. Drill 5 holes at the marked positions, at least 75mm deep. Fix the mounting bracket to the wall using 5 x M6x50 expansion bolts.

Please note: If fitting the inverter to a non-masonry wall, different fixings will be required.

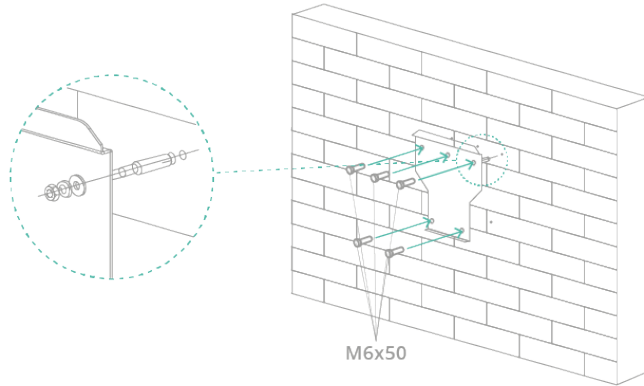

5. Mount the inverter onto the mounting bracket.

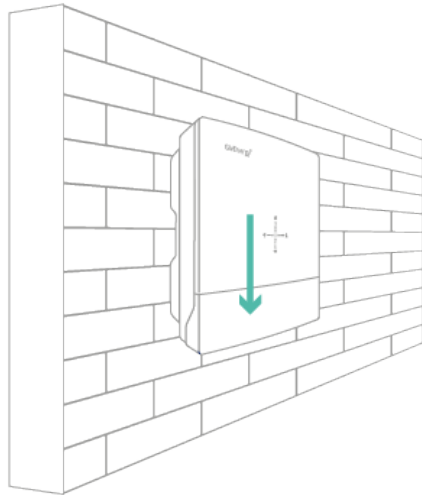

6. Insert the 2 x M4 safety locking screws on the left and right side to prevent the inverter from being lifted off the bracket.

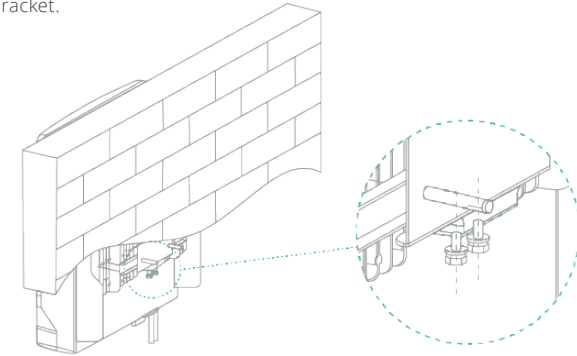

7. Remove the bottom cover. Remove the 2 screws on the bottom of the inverter with the Allen key. Pull down the bottom cover and push the grommet out of the way.

8. Make sure the DC PV isolator is switched OFF.

Wiring

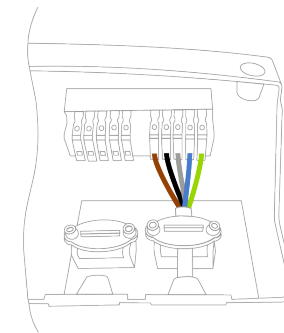

8. You must install a separate AC circuit-breaker per inverter in order to ensure that it is adequately protected and can be safely disconnected under load. Please follow local legislation.

For easy installation, you can take out the lever arch plug.

- a. Lift up the lever
- b. Connect the correct conductor to the corresponding lever
- c. Put the lever arch plug back into the inverter

To connect the AC connector:

- a. Connect the cables to their respective connection ports
- b. Cut a hole in the cable grommet
- c. Put the saddles over the cables to ensure they stay where they are
- d. For the LAN cable, make a cut down the middle of the grommet and place back in its original position

To connect the meter connections:

- a. Push and hold the orange tab
- b. Plug in the cable
- c. Release the orange tab
- d. Pull the cable slightly to ensure it is secure

The PP cable will also need to have a grommet. If installing a battery, remove the PP cable from the HV installation kit. To connect the PP cable to the inverter, make sure to use the right end of the cable. The grommet end is the inverter end.

- a. Pull down the red tab
- b. Push the connector into the socket until it clicks
- c. Push the red tab back in
- d. Check that the grommet is positioned correctly

9. Test polarity of the PV cables.
10. **4G Dongle.** Adjust all dipswitches to off and place the dongle into the USB port under the inverter. Use the securing screws to secure in place.
11. Replace the bottom front cover by sliding it up from the bottom of the inverter. Make sure that all of the grommets are seated properly. Replace the 2 securing bolts under the inverter, taking care not to overtighten.

Note: Everything is currently isolated and the inverter is not yet live.

Space Clearance

There must be adequate clearance around the inverter to allow for heat dissipation. The diagram below illustrates the space required around the inverter.



Maintenance

When maintaining and cleaning the inverter, **the whole system must be powered down**. Clean with a soft cloth with a light detergent if needed.

To ensure your inverter operates optimally at all times, annual maintenance checks need to be carried out. Check for visible damage or discolouration of the switch, and that the cables are intact. Please ensure that the top of the inverter is not obstructed in any way.

We recommend operating the rotary isolator from ON to OFF 5 times, this cleans the contacts of the rotary switch.

CONNECTIONS OVERVIEW

Item	Item Name
A	Battery connection point
B	PV Input x 2
C	Built-in WiFi aerial
D	Communication and LAN Connectors
E	EPS Connection
F	AC Connection
G	DC Input Isolation Switch
H	Cable Clamps
I	Dipswitch
J	IP65 Cable Entry Glands

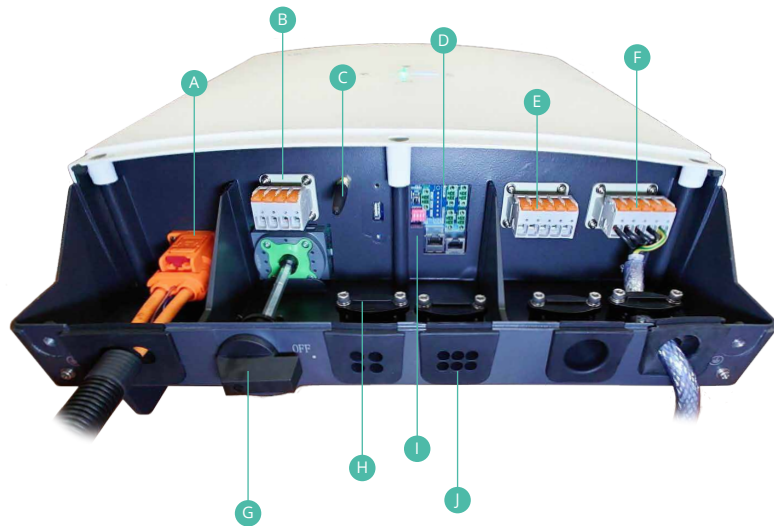

COMMUNICATION CONNECTIONS

Dip Switches

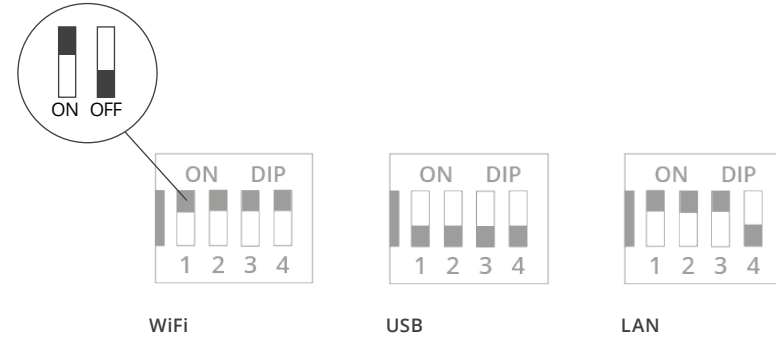

Communication/network ports

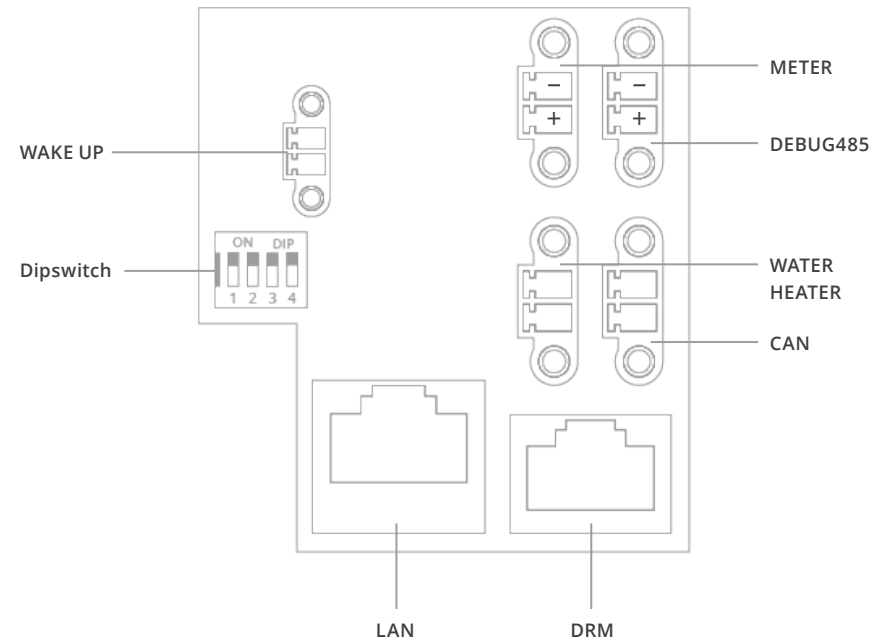

Cable size requirements for the 3-Phase Hybrid Inverter are dependent on the model and the legislation of the country it is being installed.:

- 3HY 6.0 - minimum 4mm² - 16mm²
- 3HY 8.0 - minimum 4mm² - 16mm²
- 3HY 10.0 - minimum 4mm² - 16mm²
- 3HY 11.0 - minimum 4mm² - 16mm²

The installer must calculate the size of cable needed based on the legislation and cable run length.

The Emergency Power Supply (EPS) can provide a maximum output power of up to 11000W during a grid failure. This output must be protected as close to the inverter as possible, with a double pole 30mA RCD rated at up to 20A.

There are four approved methods to connect to the EPS, please refer to the EPS Connection Guide on our Knowledge Base for more information.

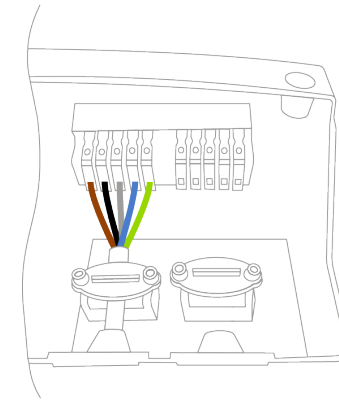

Backup
connection
terminals

If the backup terminals are used, please ensure the following:

An earth rod must be installed and connected to the main earthing terminal, as close to the origin of supply as possible, and adequate overload / short circuit protection must be installed in accordance with the local wiring regulations.



The EPS MAX output power is 11000W. If the EPS goes over its max output, the inverter will go into fault. The EPS output will only operate when the battery(s) have capacity available.

Any other grid tied generation must be supplied from the grid side of the changeover switch to avoid damage to the inverter, and void in warranty (see the following diagrams for reference).

CONNECTING GRID METER TO INVERTER

In the system, a mid approved meter must be installed to ensure correct monitoring of the grid power. The inverter uses this information to decide whether to charge or discharge the battery.

The CT clamps connected to the mid approved meter must be installed around the live incoming supply to the property, with the arrow pointing in the direction of grid import, in order to monitor the complete consumption of the building.

For further information, please refer to the meter guide on the Knowledge Base.

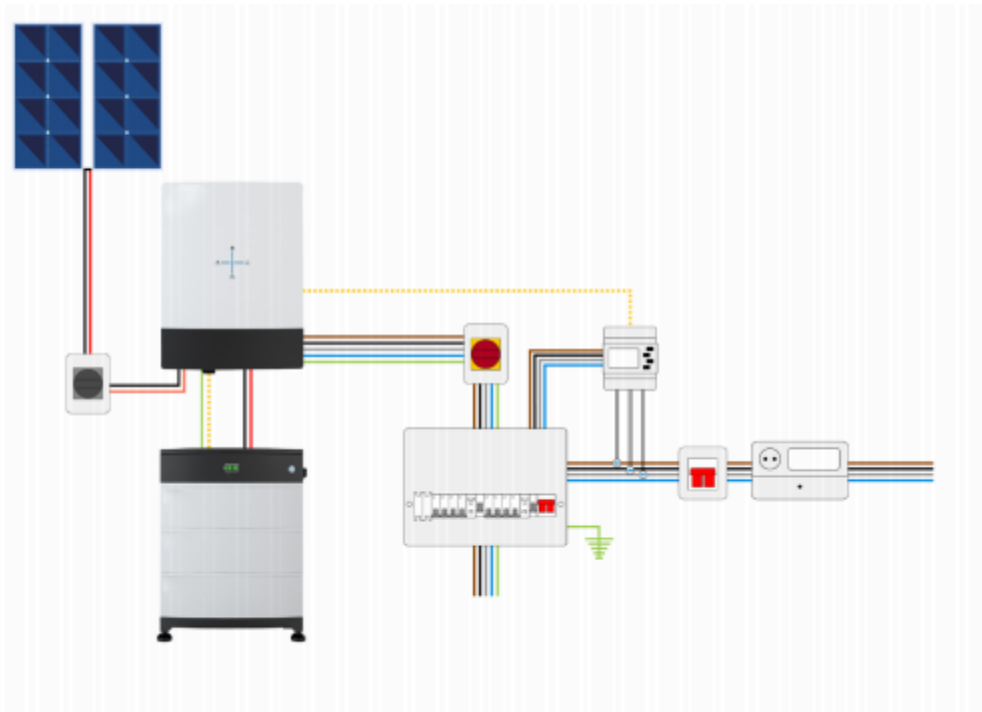

SPECIFICATIONS



STACKABLE BATTERY

Customised power, to your property

Our stackable battery is designed to work alongside the GivEnergy 3-Phase Hybrid Inverter.

High voltage BMS allows for greater charge and discharge power running at a lower current, providing higher efficiency than our lesser voltage range.

Specifications

Max. Dimensions (20.4kWh)
1085H x 380D x 480W (mm)

Max. Weight
226.3 Kg

Standard Charge/Discharge
0.5C

Max. Capacity
20.4 kWh / 51 Ah

Warranty
12 years

Max. Current
25 VDC

Voltage
187 - 520 VDC

Charging temperature
0°C - 55°

Max. Voltage
520VDC

GIV-BAT HV Kit

Item	Qty
Base Plate	1
HV Box	1
Cable Inverter to HV Box	1
Template / Positioning Part	1
Wall Bolts	2
M6 Screws (securing battery stack)	2
Plug to Plug Cable with Grommet	1

Battery (10.2kWh)

Item	Qty
Battery	3
Bat HV Kit	1
Screws	2

Battery (13.6kWh)

Item	Qty
Battery	4
Bat HV Kit	1
Screws	2

Battery (17.0kWh)

Item	Qty
Battery	5
Bat HV Kit	1
Screws	2

Battery (20.4kWh)

Item	Qty
Battery	6
Bat HV Kit	1
Screws	2

One battery is 3.4kWh. A minimum of 3 batteries is required and a maximum of 6 is possible.

Introduction

All information contained in this booklet refers to the assembly, installation, commissioning, and maintenance of the stackable batteries. Please retain this manual for future reference.

Legal Disclaimer: This document is the property of GivEnergy, reproduction is prohibited.

Installation Requirements

Installation of all GivEnergy equipment must be carried out by an **approved installer**.

HV Unit Information

The stackable batteries are designed to work with a GivEnergy 3-Phase Inverter.

Storing the Battery

The units must be stored in their original packaging at temperatures between -30°C - 60°C.

Packaging Contents

When unpacking, please check the following:

- ✔ There are no missing accessories from the packaging list
- ✔ The model and specification of the battery's nameplate match the order specifications

If any damaged or missing parts are found, please contact GivEnergy on email

info@en-ga.com immediately. Returns must be provided in original or equivalent packaging. The cardboard packaging is recyclable.

Disposing of Packaging

Recycle as much as possible and dispose of waste in the correct place.

Disposing of Hardware at the end of its lifetime

The units must be safely removed by a qualified professional. Local regulations must be adhered to and disposed of at the correct recycling place.

Item	Item Name
A	STATUS
B	ON/OFF Switch
C	HV Box
D	Rotary Isolator
E	Battery packs
F	Base plate
G	Adjustable feet
H	Securing screws
I	Earthing point
J	Battery connection point



Safety Instructions

Extra care and attention must be taken when installing and maintaining any GivEnergy equipment. The system is capable of lethal voltages, even when disconnected

- If you suspect something is wrong with the battery, contact GivEnergy on email info@en-ga.com.
- If any damaged or missing parts are found, please contact GivEnergy on email info@en-ga.com immediately. Returns must be provided in original or equivalent packaging. The cardboard packaging is recyclable.

Installation Instructions and Precautions

- All electrical installations must be carried out by a qualified and registered electrician and in accordance with the IEE Wiring Regulations
- Ensure batteries are always fixed to the wall using the mounting bracket, even when the weight of the product is on the floor
- All GivEnergy equipment must be installed by an **approved installer**
- Externally mounted batteries must always be wall mounted above the frost-line or a minimum of 50mm
- An earth bond must be installed between all batteries and inverters
- Do not remove the front cover unless instructed by the GivEnergy support team
- Only GivEnergy supplied battery cables must be used



Do not use the battery if there are any deformities, such as bulging or leakages



Do not puncture the battery



Do not throw the battery or use forceful impact



Do not attempt to repair the battery yourself (please call your Approved Installer)



The battery must be installed vertically, never install horizontally, avoid tilting the unit



Do not install in direct sunlight

STEP-BY-STEP INSTALLATION

1. Place the base plate down as close to the wall as possible. The base plate needs to be flush to the wall. Cut out the skirting board if in the way.

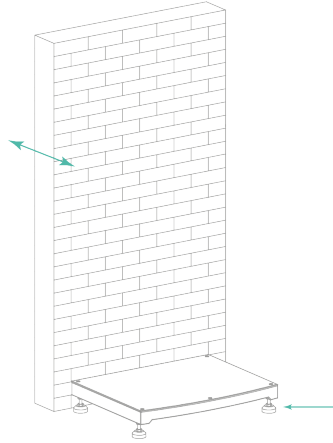

2. Stack the battery modules on the base making sure they are flush to the wall. Adjust the feet to make sure they are flush to the wall and level left and right. Once all of the battery packs are in place use the template to determine the location of the wall bolts. Ensure the template is level and completely flush to the wall.

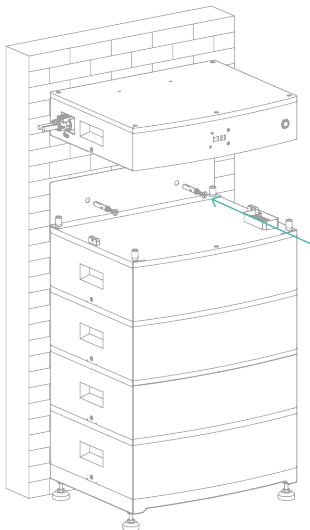

STEP-BY-STEP INSTALLATION

3. Use the template/positioning part to mark holes for the 2 bolts for the HV box.
4. Drill two holes at the marked points to suit the fixings. Install and tighten the two expanding bolts, leaving a 3mm gap between the bolt head and the wall to secure the HV Box.
5. Make sure the isolator is switched off before putting on the HV box.
6. Place the HV box on top of the batteries.

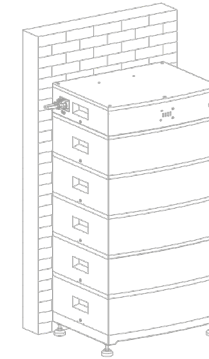

7. Connect all of the packs together (including base plate and HV Box) using the supplied screws on both sides.

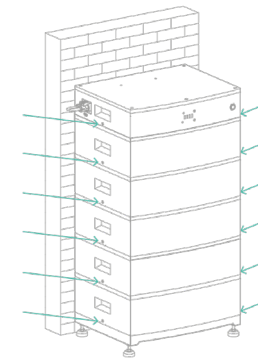

1. Connect the cable to the battery and the other end to the inverter. Ensure that the grommeted end of the cable is the inverter end. Push the plug until there is a click, lock in place using the red tab.

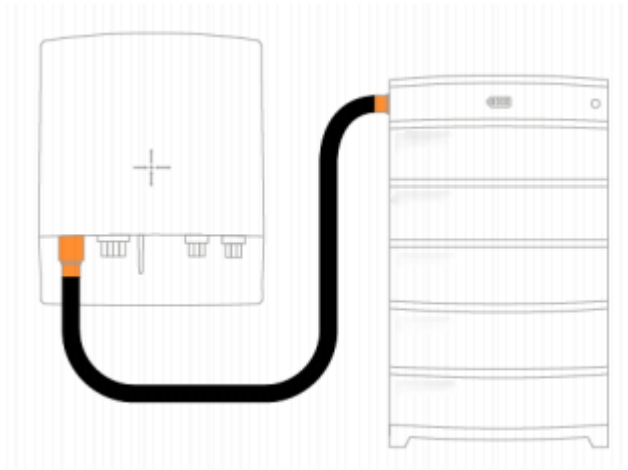

2. Make sure there is one cable (under local legislation, 6mm² earth cable suggested) running from one of the earthing points on the bottom of the inverter to the earthing point on the stackable battery.
3. When ready to power up the unit, switch on the rotary isolator on the battery. Push and hold the button for 2 seconds to switch on the battery stack. The lights should then illuminate. The system is now ready for commissioning.



One type of cables exist for connection to the stackable battery:

Plug to plug battery cable

Instructions on how to install the cable are also on the plug itself.

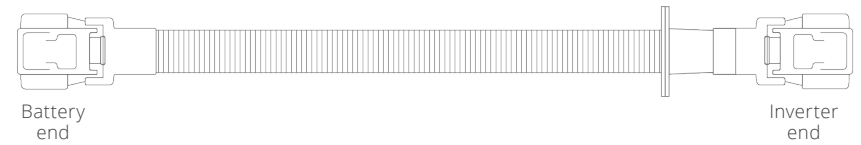

IMPORTANT

All stackable battery cables are included with the product.

Beware of inverter end and battery end.

To disconnect the cable:

1. Pull down the red tab
2. Push the red tab down
3. Press the orange tab

To connect the cable:

1. Push in the connector
2. Pull in the red tab

Note: make sure the plug is fully plugged in.

Start-Up Procedure

1. Connect the AC circuit breaker, ensure that the system is powered.
2. Check to see that the status light in the centre is flashing
3. Turn on the PV switch
4. The PV indicator should light up on the inverter (if the sun is shining)
5. Turn on the battery isolator
6. Push the button on the front of the battery until the LED lights up
7. Wait for the relays to start up
8. Make sure that the battery has a green status
9. The battery indicator on the inverter should light up
10. The system is ready to be commissioned as soon as it is powered up. Commission using the portal/app. Ensure that the grid power is reading identical to that of the mid approved meter (this can be found on the screen of the meter).

Shutdown Procedure

1. Turn off the battery by pressing the button on the front until lights have gone out
2. Switch off the battery isolator to prevent it from being reactivated
3. Turn off the PV switch
4. Disconnect the AC circuit breaker to prevent it from being reactivated
5. Wait until all LEDs have gone out. The inverter is now shut down

All systems must be commissioned to ensure correct battery and meter communications, as well as connection to the online portal.

Please ensure the following conditions are met before commissioning:

The inverter is connected to the internet and the connection guide has been followed correctly.

Check that all the wires are securely connected before the battery isolator and the AC isolator is switched on. You MUST set the parameters of the battery according to your battery system.

Accessing the Commissioning Portal

Sign into the online portal at <https://portal.en-ga.cloud> with your Engineer login. If you are a first time user, and you do not have an account or Engineer login, please consult your supplier to get this set up.

✔ To download a fully illustrated guide, please visit our Knowledge Base at www.en-ga.com

Note: If commissioning is incomplete, leave the battery off to avoid it going flat. Without commissioning, the system may not operate correctly.

Space Clearance

There must be adequate clearance around the batteries to allow for heat dissipation. The diagram below illustrates the space required around the inverter.



Maintenance

When maintaining and cleaning the stackable battery, **the whole system must be powered down**. Clean with a soft cloth with a light detergent if needed.

To ensure your stackable battery operates optimally at all times, annual maintenance checks need to be carried out. Check for visible damage or discolouration of the switch, and that the cables are intact. Please ensure that the top of the stackable battery is not obstructed in any way.

We recommend operating the rotary isolator from ON to OFF 5 times, this cleans the contacts of the rotary switch.

Status indicators



What does the STATUS light mean?

OFF	Shut down
Green	Battery Energy. Flicker - Battery charge
Green light	System boot
Red	System failure
Sound	Firmware update or a fault (please consult the app or portal)

Parameter type	GIV-BAT 10.8-HV	GIV-BAT 13.6-HV	GIV-BAT 17.0-HV	GIV-BAT 20.4-HV
Height above ground (L)	575mm	725mm	875mm	1025mm
High Voltage (UH)	262.8Vd.c	350.4Vd.c	438.0Vd.c	525.6Vd.c
Low Voltage (UL)	201.6Vd.c	268.8Vd.c	336.0Vd.c	403.2Vd.c
Measuring Voltage (UM1)	237~243Vd.c	316~324Vd.c	395~405Vd.c	474~486Vd.c
Measuring Voltage (UM2)	216Vd.c	288Vd.c	360Vd.c	432Vd.c

Uninstalling the Inverter

1. Follow the shut-down procedure
2. Remove all connections and cables from the inverter
3. Remove the bolts which are securing the inverter to the bracket
4. Lift the inverter off the bracket
5. Remove the wall bracket

Packaging the Inverter

If possible, always pack the inverter in its original packaging and secure it with tension belts. If this is not available, you may also use an equivalent sized box. The box must be capable of being closed completely and be strong enough to support both the weight and the size of the inverter.

Storing the Inverter

Store the inverter in a dry place where ambient temperatures are always between -25°C and +60°C

Uninstalling a Battery

1. Follow the shut-down procedure
2. Remove all cables
3. Remove the bolts securing the HV box
4. Lift the HV box
5. Lift off all of the battery packs
6. Remove the base plate

WORK MODES & TROUBLESHOOTING



Eco Mode

The system optimises the delivery of generated PV power and battery power to prioritise the home load. Grid power is used as a last resort if solar and battery power are unavailable.



Off Peak Charging

This is prioritised to charge the battery during off peak times when energy is cheaper, greener, and cleaner. The battery will start to discharge outside of the off peak time when energy is more expensive.



Back Up / Island Mode

The system has the ability to be used in the event of a power cut. To utilise this feature, circuits must be connected to the inverter's EPS terminals.

To download a fully illustrated guide on connecting the inverter to the EPS, please visit our Knowledge Base at www.en-ga.com

If you have any questions, please contact GivEnergy on email info@en-ga.com. Alternatively, visit our troubleshooting guide on the knowledge base at www.en-ga.com

MANUFACTURER WARRANTIES

This inverter and stackable battery are covered by a 12-year warranty. Please refer to the warranty document for further specifications.

Products Covered



**Hybrid Inverter Gen 3
3-Phase 6.0**
10 years



**Hybrid Inverter Gen 3
3-Phase 8.0**
10 years



**Hybrid Inverter Gen 3
3-Phase 10.0**
10 years



**Hybrid Inverter Gen 3
3-Phase 11.0**
10 years



Stackable Battery | HV 10.2/ 13.6/ 17.0/ 20.4
10 years

